

Lengths (mm)	L1	L2	L3
	Overall Tray Length	Internal Tray Length	Internal with Rear Rack
Standard Length	1732	1647	1552
Extend Tray Length - 88mm	1820	1735	1640
Extend Tray Length - 177mm	1909	1824	1729
Extend Tray Length - 265mm	1997	1912	1817
Widths (mm)	W1	W2	W2
	Overall Tray Width	Internal Tray Width	Internal with Rear Rack
	1890	1832	1720
Heights (mm)	H1	H1	H2
	Standard Height	Height with Trundle Tray	Height to Floor 225mm Drop Side
	940	940	244

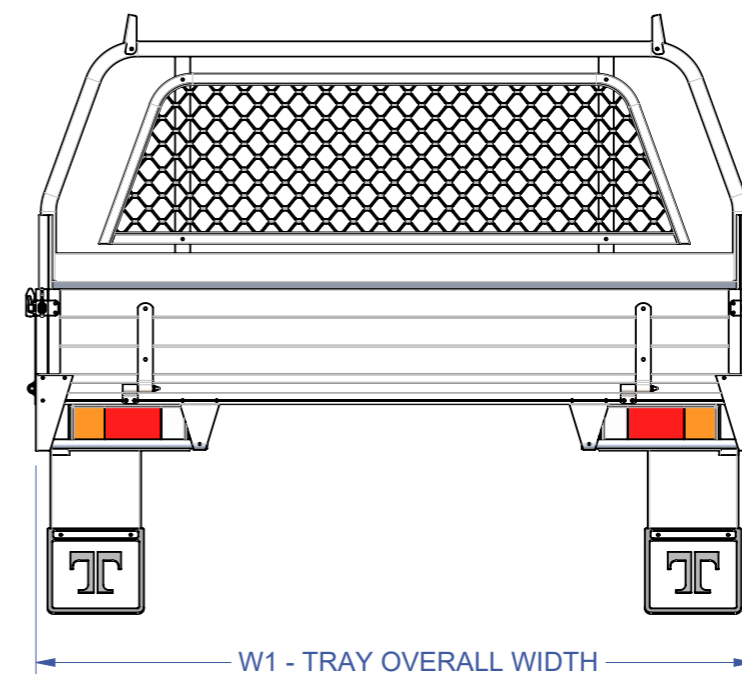

Note: Tip Top Equipment reserves the right to change specifications, materials used, and prices at any time.

## TOOLBOXES

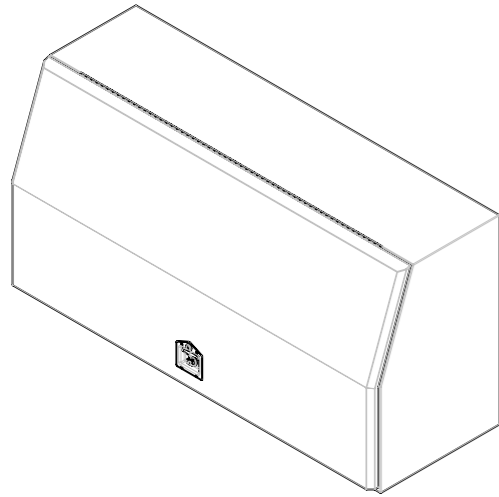

**TAJ 1425**  
2mm ALUMINIUM CHECKER PLATE  
1425L x 850H x 600D

**TAJ 1700**  
2mm ALUMINIUM CHECKER PLATE  
1700L x 850H x 600D

## TRUNDLE TRAYS

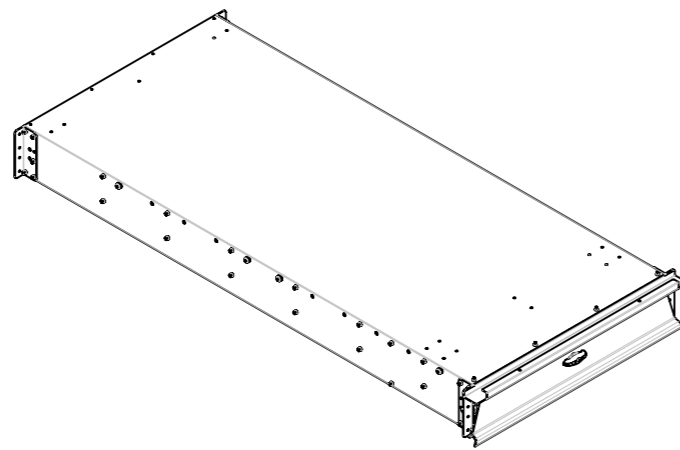

**QTT 1500**  
External: 1500L x 750W x 170H  
Internal: 1440L x 680W x 134H

**QTT 1800**  
External: 1800L x 750W x 170H  
Internal: 1740L x 680W x 134H

**QTT 2100**  
External: 2100L x 750W x 170H  
Internal: 2040L x 680W x 134H

## UNDER BODY BOXES

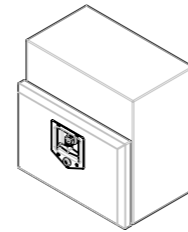

**ROPE BOX**  
QT B 40  
ALUMINIUM  
CHECKER PLATE  
400L x 400H x 270D



**HANDWASH UNIT**  
QHW 15  
BLACK POLY  
340L x 300H x 250D

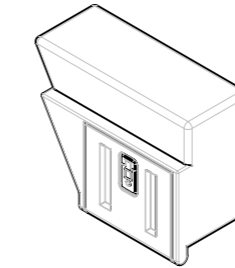

**ROPE BOXES**  
RB 375B L/R  
BLACK POLY  
590L x 400H x 270D

RB 550B L/R  
BLACK POLY  
740L x 400H x 270D

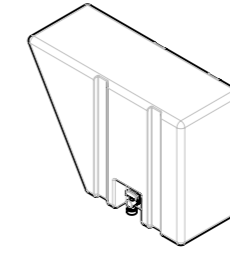

**WATER TANKS**  
UWT 35LB L/R  
BLACK POLY  
590L x 400H x 270D

UWT 55LB L/R  
BLACK POLY  
740L x 400H x 270D

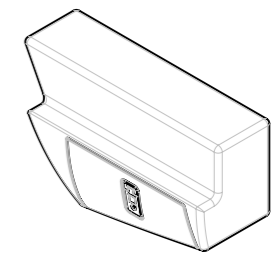

**SPORTS PANNIER BOXES**  
PS 520B L/R  
BLACK POLY  
740L x 270D

PS 675B L/R  
BLACK POLY  
900L x 270D

Ranger / Mazda BT-50 Double Cab		Tool Boxes		Trundle Tray Storage Drawer			Under Body Boxes Front - Passenger				Front - Drivers Side				Rear - Both Sides							
L1 Overall Tray Length mm	Rear Rack	TAJ 1425	TAJ 1700	QTT1500	QTT1800	QTT2100	QT B40	QHW15	RB375B L	RB550B L	QT B40	QHW15	RB375B R	RB550B R	QT B40	QHW15	RB375B L/R	RB550B L/R	UWT35LB L/R	UWT55LB L/R	PS520B L/R	PS675B L/R
1732	No	●		●											●	●	●	●	●	●	●	●
	Yes			●											●	●	●	●	●	●	●	●
1820	No	●		●											●	●	●	●	●	●	●	●
	Yes			●											●	●	●	●	●	●	●	●
1909	No	●	●	●											●	●	●	●	●	●	●	●
	Yes	●		●											●	●	●	●	●	●	●	●
1997	No	●	●	●	●										●	●	●	●	●	●	●	●
	Yes	●		●	●										●	●	●	●	●	●	●	●

Note: Tip Top Equipment reserves the right to change specifications, materials used, and prices at any time.