

Lengths (mm)	L1	L2	L3
	Overall Tray Length	Internal Tray Length	Internal with Rear Rack
Standard Length	1732	1647	1552
Extend Tray Length - 88mm	1820	1735	1640
Extend Tray Length - 177mm	1909	1824	1729
Extend Tray Length - 265mm	1997	1912	1817
Widths (mm)	W1	W2	W2
	Overall Tray Width	Internal Tray Width	Internal with Rear Rack
	1890	1832	1720
Heights (mm)	H1	H1	H2
	Standard Height	Height with Trundle Tray	Height to Floor 225mm Drop Side
	900	875	244

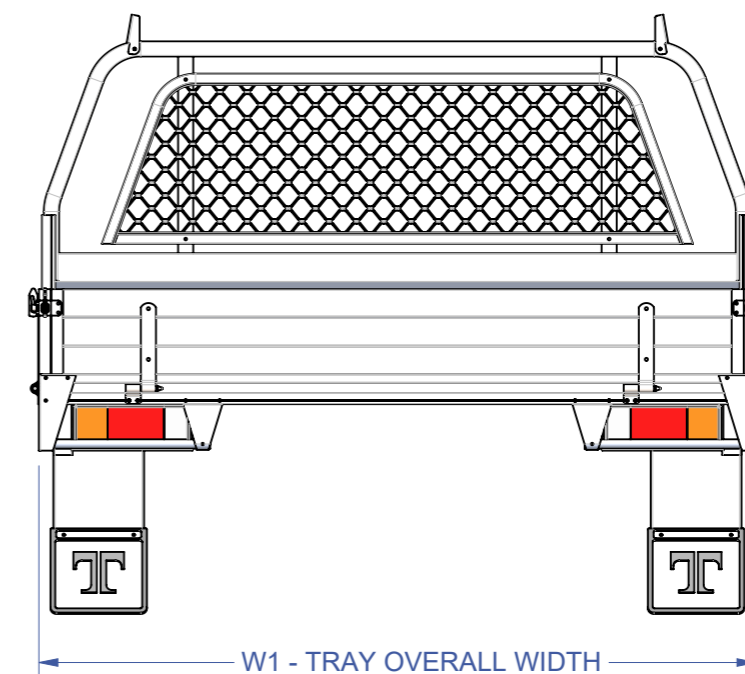

Note: Tip Top Equipment reserves the right to change specifications, materials used, and prices at any time.

TOOLBOXES

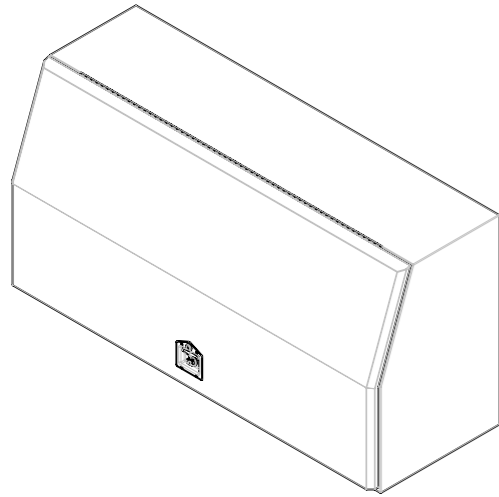

TAJ 1425
2mm ALUMINIUM CHECKER PLATE
1425L x 850H x 600D

TAJ 1700
2mm ALUMINIUM CHECKER PLATE
1700L x 850H x 600D

TRUNDLE TRAYS

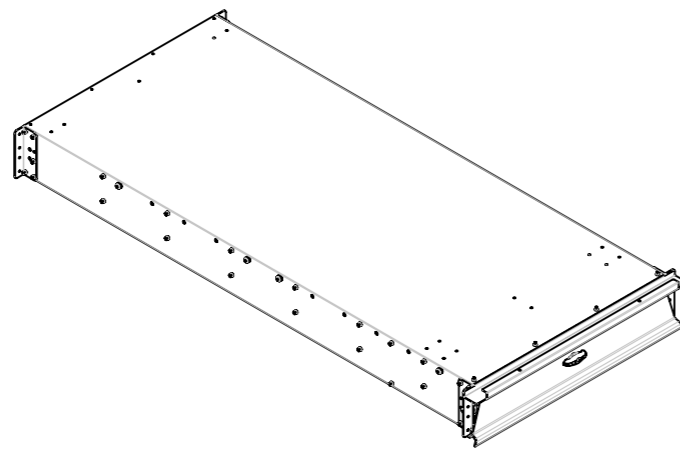

QTT 1500
External: 1500L x 750W x 170H
Internal: 1440L x 680W x 134H

QTT 1800
External: 1800L x 750W x 170H
Internal: 1740L x 680W x 134H

QTT 2100
External: 2100L x 750W x 170H
Internal: 2040L x 680W x 134H

UNDER BODY BOXES

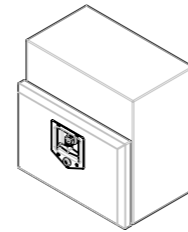

ROPE BOX
QT B40
ALUMINIUM
CHECKER PLATE
400L x 400H x 270D



HANDWASH UNIT
QHW 15
BLACK POLY
340L x 300H x 250D

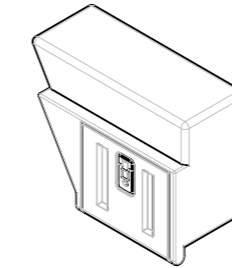

ROPE BOXES
RB 375B L/R
BLACK POLY
590L x 400H x 270D

RB 550B L/R
BLACK POLY
740L x 400H x 270D

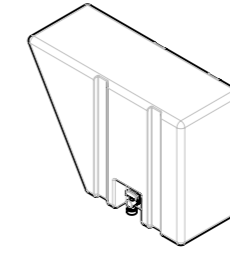

WATER TANKS
UWT 35LB L/R
BLACK POLY
590L x 400H x 270D

UWT 55LB L/R
BLACK POLY
740L x 400H x 270D

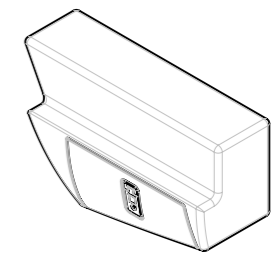

SPORTS PANNIER BOXES
PS 520B L/R
BLACK POLY
740L x 270D

PS 675B L/R
BLACK POLY
900L x 270D

Nissan Navara Dual Cab		Tool Boxes		Trundle Tray Storage Drawer			Under Body Boxes Front - Passenger				Front - Drivers Side				Rear - Both Sides								
L1 Overall Tray Length mm	Rear Rack	TAJ 1425	TAJ 1700	QTT1500	QTT1800	QTT2100	QT B40	QHW15	RB375B L	RB550B L	QT B40	QHW15	RB375B R	RB550B R	QT B40	QHW15	RB375B L/R	RB550B L/R	UWT35LB L/R	UWT55LB L/R	PS520B L/R	PS675B L/R	
1732	No	●		●											●	●	●	●	●	●	●		
	Yes			●											●	●	●	●	●	●	●		
1820	No	●		●											●	●	●	●	●	●	●		
	Yes			●											●	●	●	●	●	●	●		
1909	No	●	●	●											●	●	●	●	●	●	●	●	●
	Yes			●											●	●	●	●	●	●	●		
1997	No	●	●	●	●										●	●	●	●	●	●	●	●	●
	Yes			●	●										●	●	●	●	●	●	●		

Note: Tip Top Equipment reserves the right to change specifications, materials used, and prices at any time.