

Mitsubishi Triton - Dual Cab	Tradesman Tray		
<b>Lengths (mm)</b>	<b>L1</b>	<b>L2</b>	<b>L3</b>
	Overall	Internal	Clear with
	Tray Length	Tray Length	Rear Rack
Standard Length	1732	1587	1392
Extend Tray Length - 88mm	1820	1675	1480
Extend Tray Length - 177mm	1909	1764	1569
<b>Widths (mm)</b>	<b>W1</b>	<b>W2</b>	<b>W3</b>
	Overall	Internal	Clear with
	Tray Width	Tray Width	Rear Rack
	1890	1832	1630
<b>Heights (mm)</b>	<b>H1</b>	<b>H1</b>	<b>H2</b>
	Standard	Height with	Height to Floor
	Height	Trundle Tray	225mm Drop Side
	905	905	244

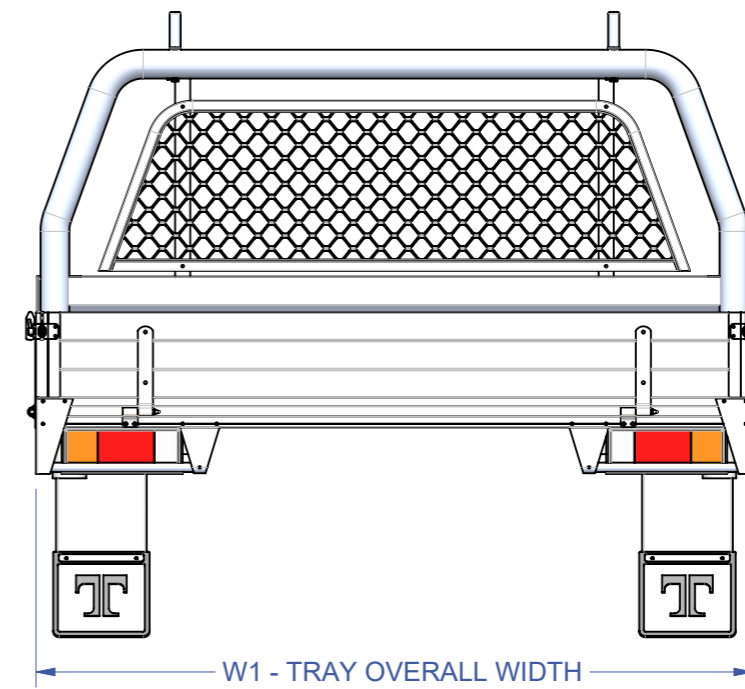

Note: Tip Top Equipment reserves the right to change specifications, materials used, and prices at any time.

## TOOLBOXES

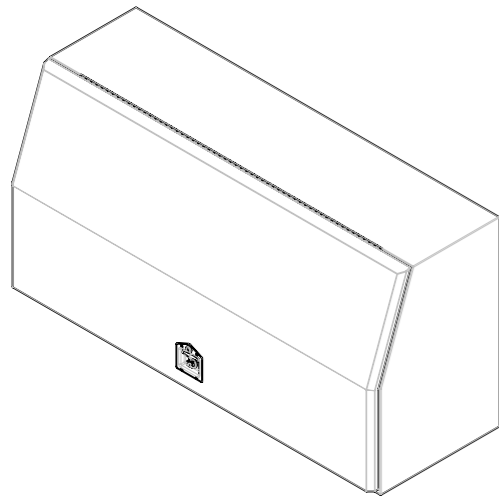

**TAJ 1425**  
2mm ALUMINIUM CHECKER PLATE  
1425L x 850H x 600D

**TAJ 1700**  
2mm ALUMINIUM CHECKER PLATE  
1700L x 850H x 600D

## TRUNDLE TRAYS

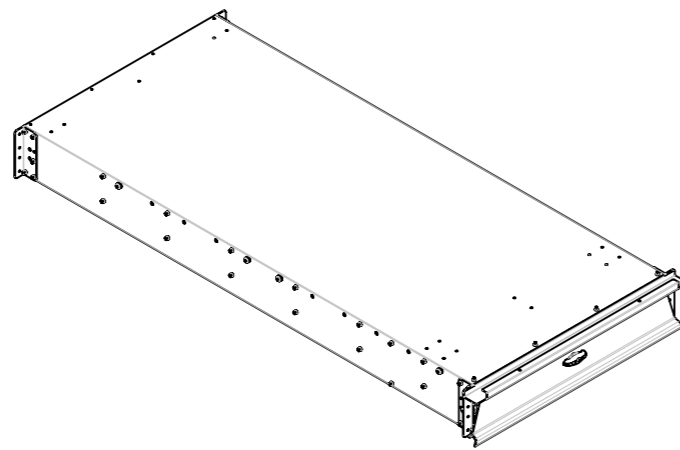

**QTT 1500**  
External: 1500L x 750W x 170H  
Internal: 1440L x 680W x 134H

**QTT 1800**  
External: 1800L x 750W x 170H  
Internal: 1740L x 680W x 134H

**QTT 2100**  
External: 2100L x 750W x 170H  
Internal: 2040L x 680W x 134H

## UNDER BODY BOXES

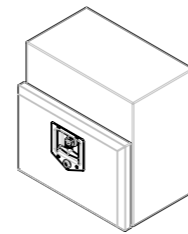

**ROPE BOX**  
QT B40  
ALUMINIUM  
CHECKER PLATE  
400L x 400H x 270D



**HANDWASH UNIT**  
QHW 15  
BLACK POLY  
340L x 300H x 250D

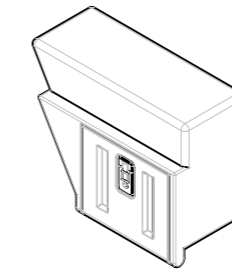

**ROPE BOXES**  
RB 375B L/R  
BLACK POLY  
590L x 400H x 270D

RB 550B L/R  
BLACK POLY  
740L x 400H x 270D

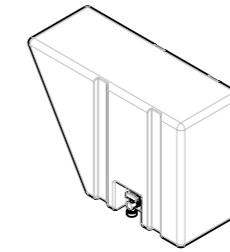

**WATER TANKS**  
UWT 35LB L/R  
BLACK POLY  
590L x 400H x 270D

UWT 55LB L/R  
BLACK POLY  
740L x 400H x 270D

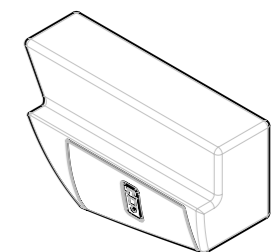

**SPORTS PANNIER BOXES**  
PS 520B L/R  
BLACK POLY  
740L x 270D

PS 675B L/R  
BLACK POLY  
900L x 270D

Mitsubishi Triton Dual Cab		Tool Boxes		Trundle Tray Storage Drawer			Under Body Boxes Front - Passenger				Front - Drivers Side				Rear - Both Sides							
L1 Overall Tray Length mm	Rear Rack	TAJ 1425	TAJ 1700	QTT1500	QTT1800	QTT2100	QT B40	QHW15	RB375B L	RB550B L	QT B40	QHW15	RB375B R	RB550B R	QT B40	QHW15	RB375B L/R	RB550B L/R	UWT35LB L/R	UWT55LB L/R	PS520B L/R	PS675B L/R
1732	No	●		●											●	●	●	●	●	●	●	●
	Yes			●											●	●	●	●	●	●	●	●
1820	No	●		●											●	●	●	●	●	●	●	●
	Yes			●											●	●	●	●	●	●	●	●
1909	No	●	●	●											●	●	●	●	●	●	●	●
	Yes	●		●											●	●	●	●	●	●	●	●

Note: Tip Top Equipment reserves the right to change specifications, materials used, and prices at any time.