

Ranger / BT-50 - Super Cab / Freestyle Cab	Tradesman Tray		
Lengths (mm)	L1	L2	L3
	Overall	Internal	Clear with
	Tray Length	Tray Length	Rear Rack
Standard Length	2090	1945	1750
Extend Tray Length - 88mm	2178	2033	1838
Extend Tray Length - 177mm	2267	2122	1927
Extend Tray Length - 265mm	2355	2210	2015
Widths (mm)	W1	W2	W3
	Overall	Internal	Clear with
	Tray Width	Tray Width	Rear Rack
	1890	1832	1630
Heights (mm)	H1	H1	H2
	Standard	Height with	Height to Floor
	Height	Trundle Tray	225mm Drop Side
	940	915	244

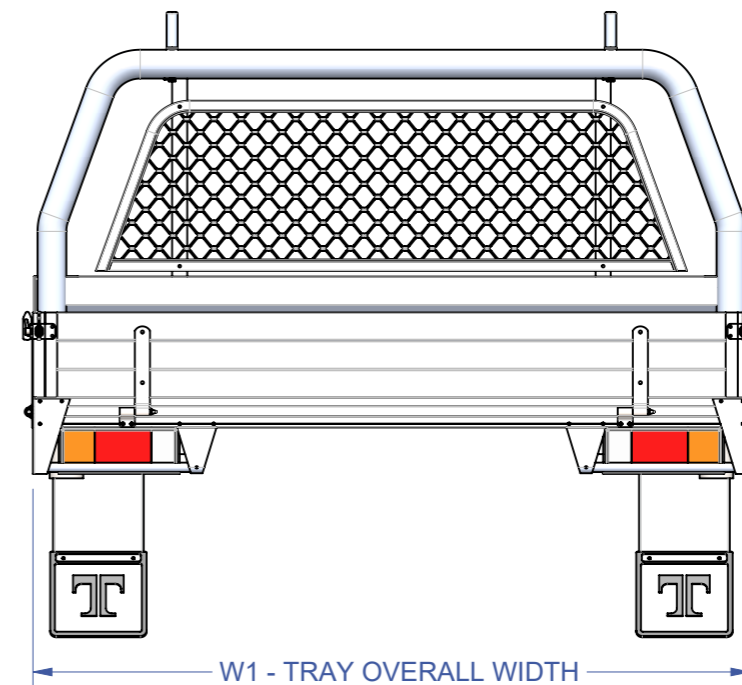

Note: Tip Top Equipment reserves the right to change specifications, materials used, and prices at any time.

TOOLBOXES

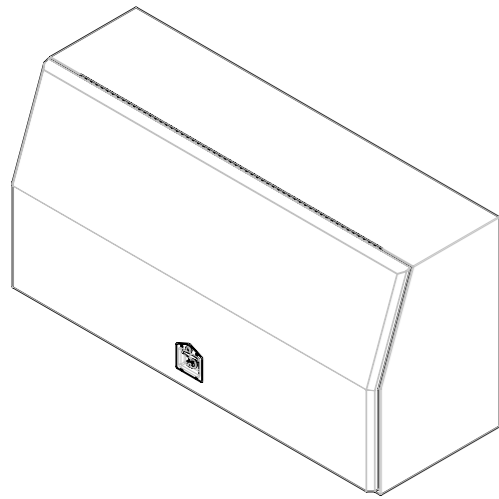

TAJ 1425
2mm ALUMINIUM CHECKER PLATE
1425L x 850H x 600D

TAJ 1700
2mm ALUMINIUM CHECKER PLATE
1700L x 850H x 600D

TRUNDLE TRAYS

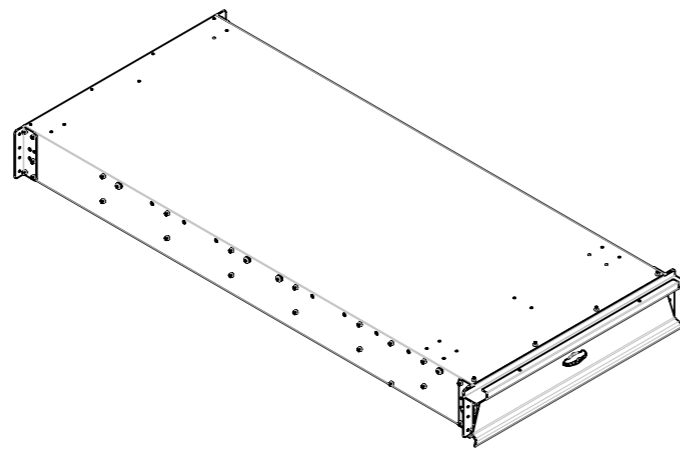

QTT 1500
External: 1500L x 750W x 170H
Internal: 1440L x 680W x 134H

QTT 1800
External: 1800L x 750W x 170H
Internal: 1740L x 680W x 134H

QTT 2100
External: 2100L x 750W x 170H
Internal: 2040L x 680W x 134H

UNDER BODY BOXES

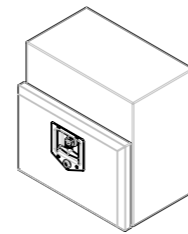

ROPE BOX
QT B40
ALUMINIUM
CHECKER PLATE
400L x 400H x 270D

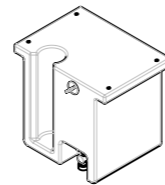

HANDWASH UNIT
QHW 15
BLACK POLY
340L x 300H x 250D

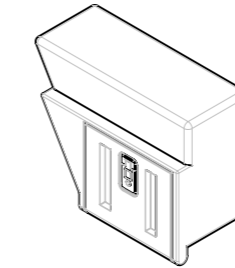

ROPE BOXES
RB 375B L/R
BLACK POLY
590L x 400H x 270D

RB 550B L/R
BLACK POLY
740L x 400H x 270D

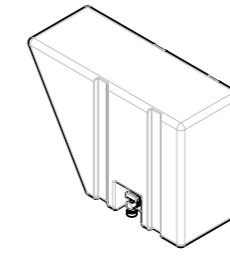

WATER TANKS
UWT 35LB L/R
BLACK POLY
590L x 400H x 270D

UWT 55LB L/R
BLACK POLY
740L x 400H x 270D

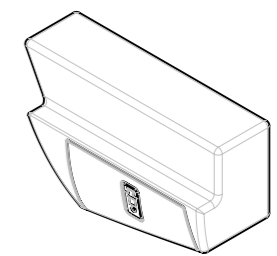

SPORTS PANNIER BOXES
PS 520B L/R
BLACK POLY
740L x 270D

PS 675B L/R
BLACK POLY
900L x 270D

Ranger / Mazda BT-50 Super / Freestyle Cab		Tool Boxes		Trundle Tray Storage Drawer			Under Body Boxes Front - Passenger				Front - Drivers Side				Rear - Both Sides							
		TAJ 1425	TAJ 1700	QTT 1500	QTT 1800	QTT 2100	QT B40	QHW 15	RB 375B L	RB 550B L	QT B40	QHW 15	RB 375B R	RB 550B R	QT B40	QHW 15	RB 375B L/R	RB 550B L/R	UWT 35LB L/R	UWT 55LB L/R	PS 520B L/R	PS 675B L/R
L1 Overall Tray Length mm	No	●	●	●	●									●	●	●	●	●	●	●	●	●
	Yes	●	●	●	●									●	●	●	●	●	●	●	●	●
2178	No	●	●	●	●									●	●	●	●	●	●	●	●	●
	Yes	●	●	●	●									●	●	●	●	●	●	●	●	●
2267	No	●	●	●	●	●								●	●	●	●	●	●	●	●	●
	Yes	●	●	●	●	●								●	●	●	●	●	●	●	●	●
2355	No	●	●	●	●	●								●	●	●	●	●	●	●	●	●
	Yes	●	●	●	●	●								●	●	●	●	●	●	●	●	●

Note: Tip Top Equipment reserves the right to change specifications, materials used, and prices at any time.